



2019 SANTA FE



- ① EMBARGO: Drive Impressions August 27, 12:01 a.m. EDT
- ② Q&A: after the presentation
- ③ PRESENTATION: on the flash drive



Mike O'Brien

VP, Product, Corporate & Digital Planning



With U.S. production capacity at

400,000 units,

the majority of Hyundai vehicles sold in the U.S. are produced here.



- Provides nearly **3,000 jobs** to Alabama residents
- Three of our top-selling models – Elantra, Sonata and Santa Fe – are built here
- A **\$388M** addition to an engine plant to prepare for next-generation engine

ECONOMIC OUTLOOK REMAINS STRONG

~17M

vehicle sales are expected in the
U.S. market in 2018

Industry

↓ ~2% vs. 2017

#4 IMPORT BRAND IN THE U.S.

2000	2001	2002	2003	2004	'05/'06	2007	2008	2009	2010	2011	2012	2013	2014	2015	2016	2017
Toyota	Toyota	Toyota	Toyota	Toyota	Toyota	Toyota	Toyota	Toyota	Toyota	Toyota	Toyota	Toyota	Toyota	Toyota	Toyota	Toyota
Honda	Honda	Honda	Honda	Honda	Honda	Honda	Honda	Honda	Honda	Honda	Honda	Honda	Honda	Honda	Honda	Honda
Nissan	Nissan	Nissan	Nissan	Nissan	Nissan	Nissan	Nissan	Nissan	Nissan	Nissan	Nissan	Nissan	Nissan	Nissan	Nissan	Nissan
VW	VW	Hyundai	Hyundai	Hyundai	Hyundai	Hyundai	Hyundai	Hyundai	Hyundai	Hyundai	Hyundai	Hyundai	Hyundai	Hyundai	Hyundai	Hyundai
Mitsubishi	Hyundai	Mitsubishi	VW	Lexus	Lexus	Lexus	Kia	Kia	Kia	Kia	Kia	Kia	Kia	Kia	Kia	Subaru
Mazda	Mitsubishi	VW	Lexus	Kia	Kia	Kia	Mazda	Subaru	VW	VW	VW	Subaru	Subaru	Subaru	Subaru	Kia
Hyundai	Mazda	Mazda	Mazda	Mazda	BMW	Mazda	Lexus	Lexus	Subaru	Subaru	Subaru	VW	VW	Mercedes	Mercedes	Mercedes
Lexus	Lexus	Kia	Mitsubishi	BMW	Mazda	BMW	BMW	VW	Mazda	Mercedes	Mercedes	Mercedes	Mercedes	VW	Lexus	VW
Mercedes	Kia	Lexus	BMW	VW	Mercedes	Mercedes	Mercedes	Mazda	Lexus	Mazda	BMW	BMW	BMW	BMW	VW	BMW
BMW	BMW	BMW	Kia	Mercedes	VW	VW	VW	BMW	Mercedes	BMW	Mazda	Mazda	Lexus	Lexus	BMW	Lexus

*Source: IHS Sales Forecast

IMPROVING PRODUCT MIX

INDUSTRY

Truck Segment Share Increased

+4.9%

<u>Industry</u>	Share	PPT ▲
Truck Segments	68.6%	+4.9ppt

HYUNDAI

Truck Segment Share Increased

+9.6%

<u>Hyundai</u>	<u>Share</u>	PPT ▲
Truck Segments	43.5%	+9.6ppt

**Industry Sales Report- July 2018; CYTD data displayed*

TOP SAFETY PICKS WITH SEVEN MODELS

2018
IIHS

TOP
SAFETY
PICK+

SONATA
SANTA FE
SANTA FE SPORT

2018
IIHS

TOP
SAFETY
PICK

IONIQ Hybrid
ELANTRA / GT
SONATA
TUCSON



INDUSTRY-LEADING OWNERSHIP VALUE

Hyundai #1



2018 **5-YEAR
COST TO OWN
AWARDS**



Hyundai consistently earns highest fuel economy gains in the study by EPA.

MY2015 – MY2016 Manufacturer Adjusted Fuel Economy and Adjusted CO₂ Emissions

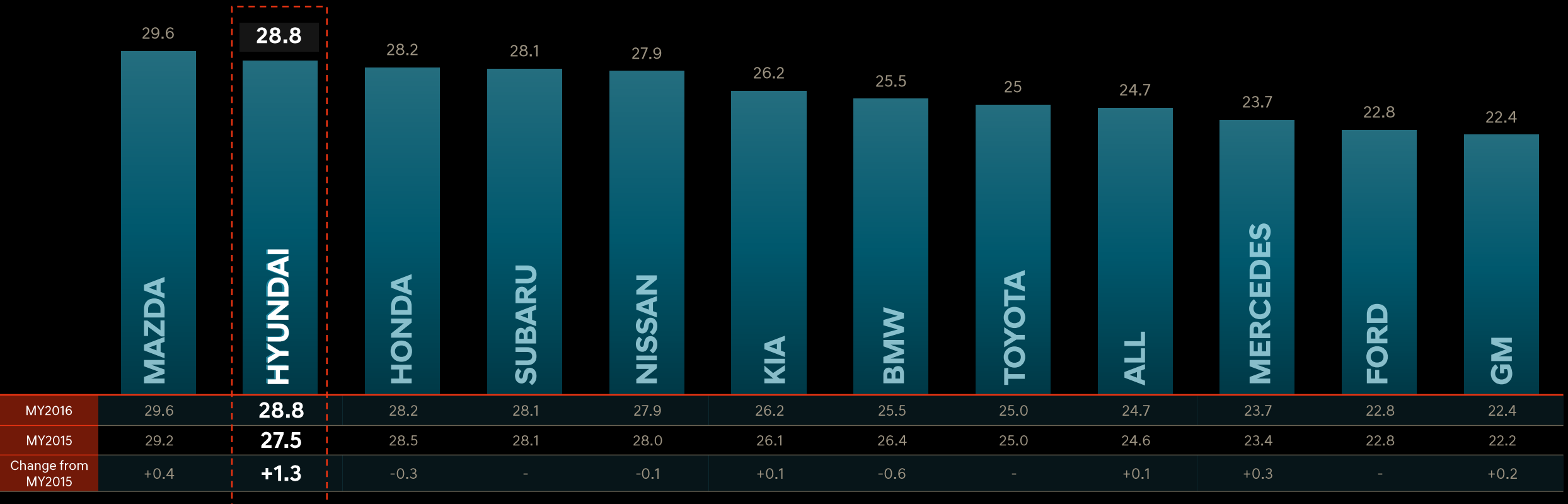

Shopper Assurance



Offering customers convenient ways to schedule a test drive either at a customer desired location or at the dealership.



Flexible Test Drive

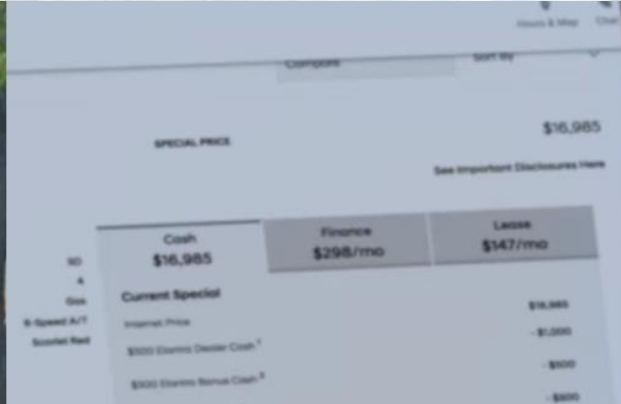

Customers see dealer pricing that reflects MSRP minus: in-market cash incentives and any dealer offered discounts on the dealer website.



Transparent Pricing

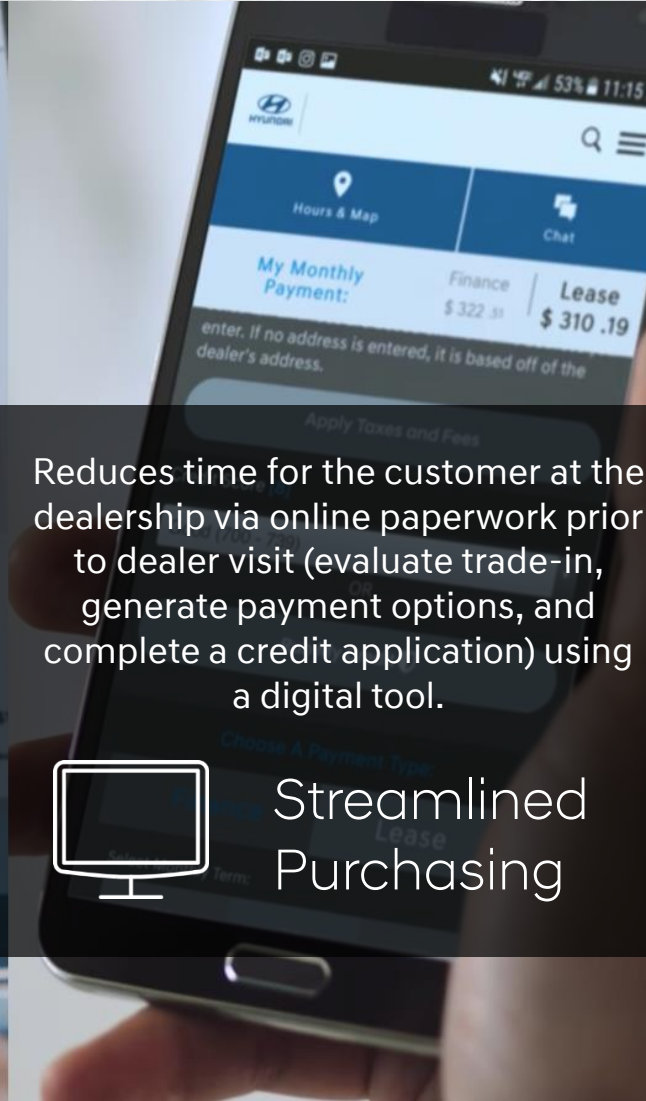

Reduces time for the customer at the dealership via online paperwork prior to dealer visit (evaluate trade-in, generate payment options, and complete a credit application) using a digital tool.



Streamlined Purchasing

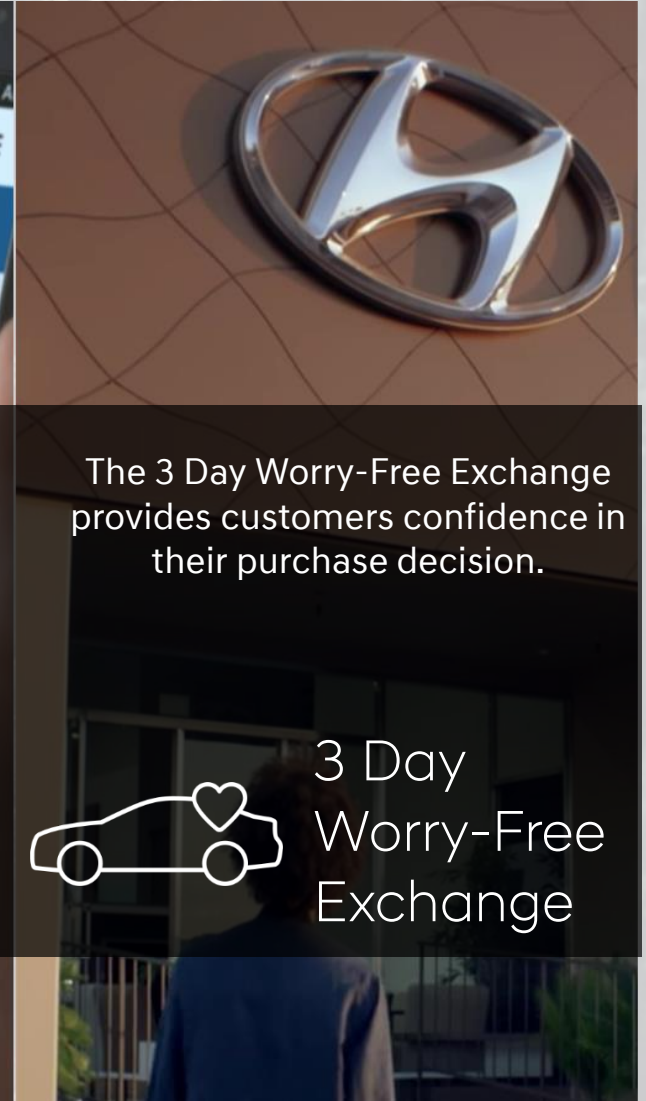

The 3 Day Worry-Free Exchange provides customers confidence in their purchase decision.

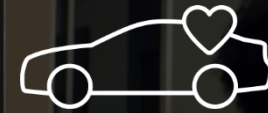

3 Day Worry-Free Exchange



2019 SANTA FE

INTRODUCTION

BUYERS WANT MORE UTILITY

CY17 vs CY14
Segment Sales

83%



Small SUV

KONA

27%



Subcompact SUV

TUCSON

12%



Compact SUV

SANTAFE

28%



Midsize SUV

SANTAFE
XL

*IHS Sales Figures

CONSISTENT COMPACT SUV VOLUME OVER 1M/YR

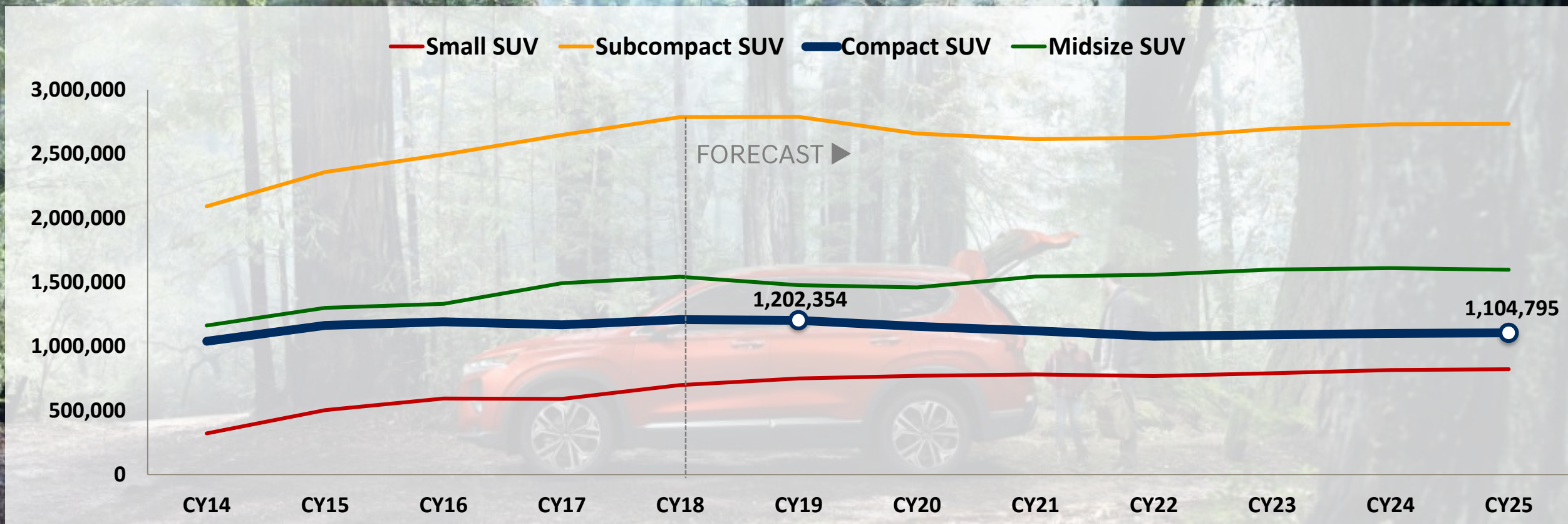

*IHS Sales & Forecast

HYUNDAI SUV SALES MIX IS RISING

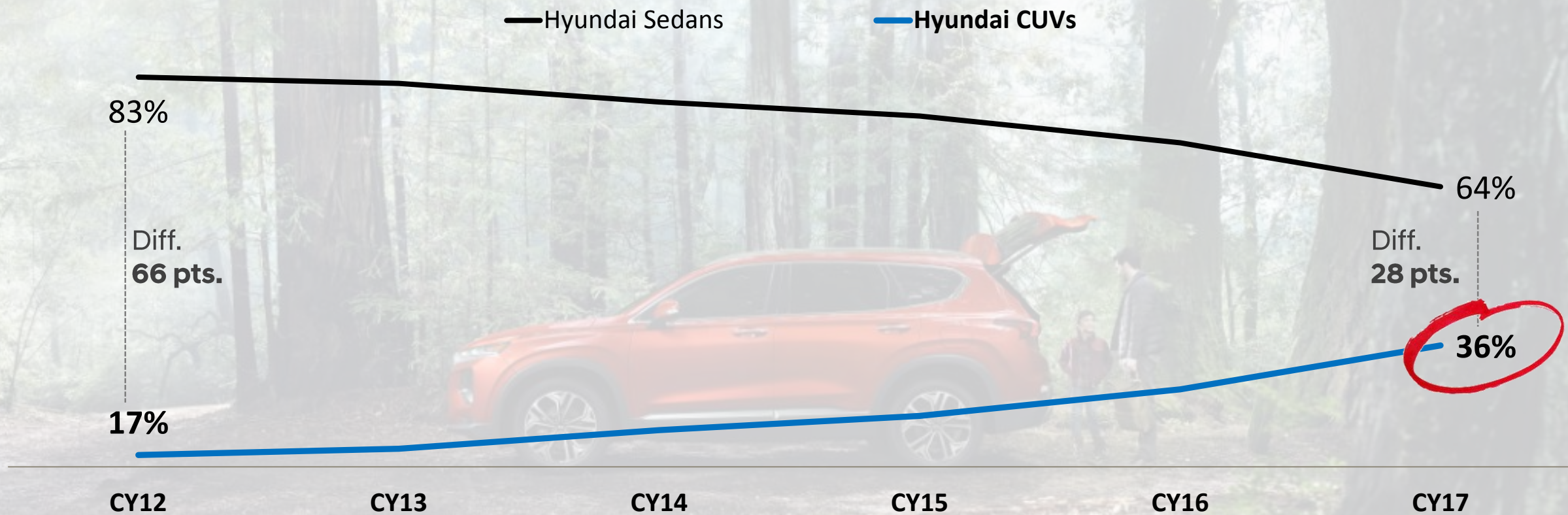

*HMA Sales Report

COMPACT SUV COMPETITORS



Ford Edge



Nissan Murano



Jeep Cherokee



Subaru Outback



Kia Sorento



Chevrolet Blazer

EXTERIOR DIMENSIONS

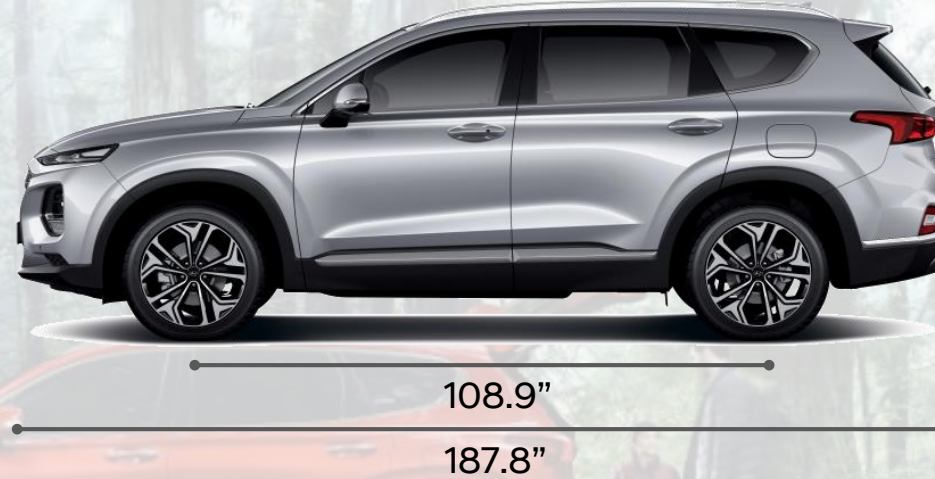

Dimensions (in.)	Santa Fe Sport	Delta	Santa Fe	Edge	Murano	Cherokee	Outback	Sorento
Length	185.0	+2.8	187.8	188.1	192.8	182.0	189.6	189.0
Width	74.0	+0.4	74.4	75.9	75.4	73.2	72.4	74.4
Height	66.5	+0.6	67.1	68.6	67.8	66.2	66.5	66.5
Wheelbase	106.3	+2.6	108.9	112.2	111.2	106.6	108.1	109.4

*JATO V5

LIGHTEST SUV AMONG COMPETITORS

Curb Weight (lbs.)

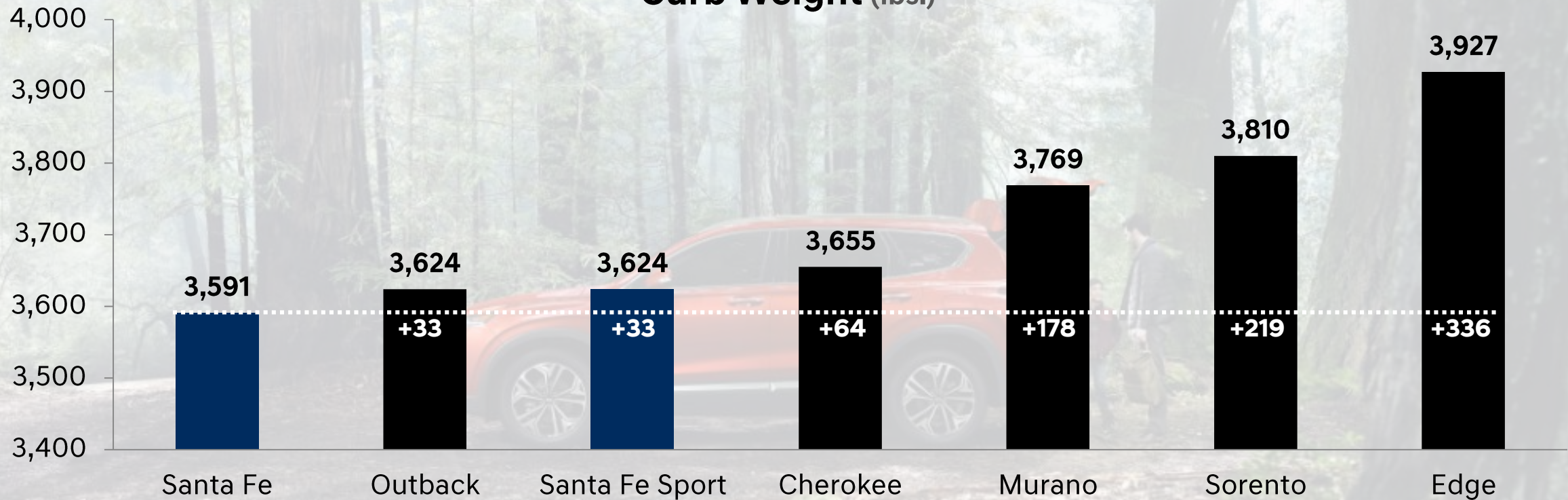

*AutoPlanner

COMPETITIVE & VERSATILE CARGO SPACE

CARGO SOLUTIONS

- ★ 60/40 2nd Row Fold Flat Seats
- ★ Cargo-Area Seat Release (buttons release 2nd row seats)
- ★ Cargo Underfloor Storage (Tray and Hidden Compartment)
- ★ Selectable Liftgate Speed
Standard: 6.0 sec
Express: 4.5 sec

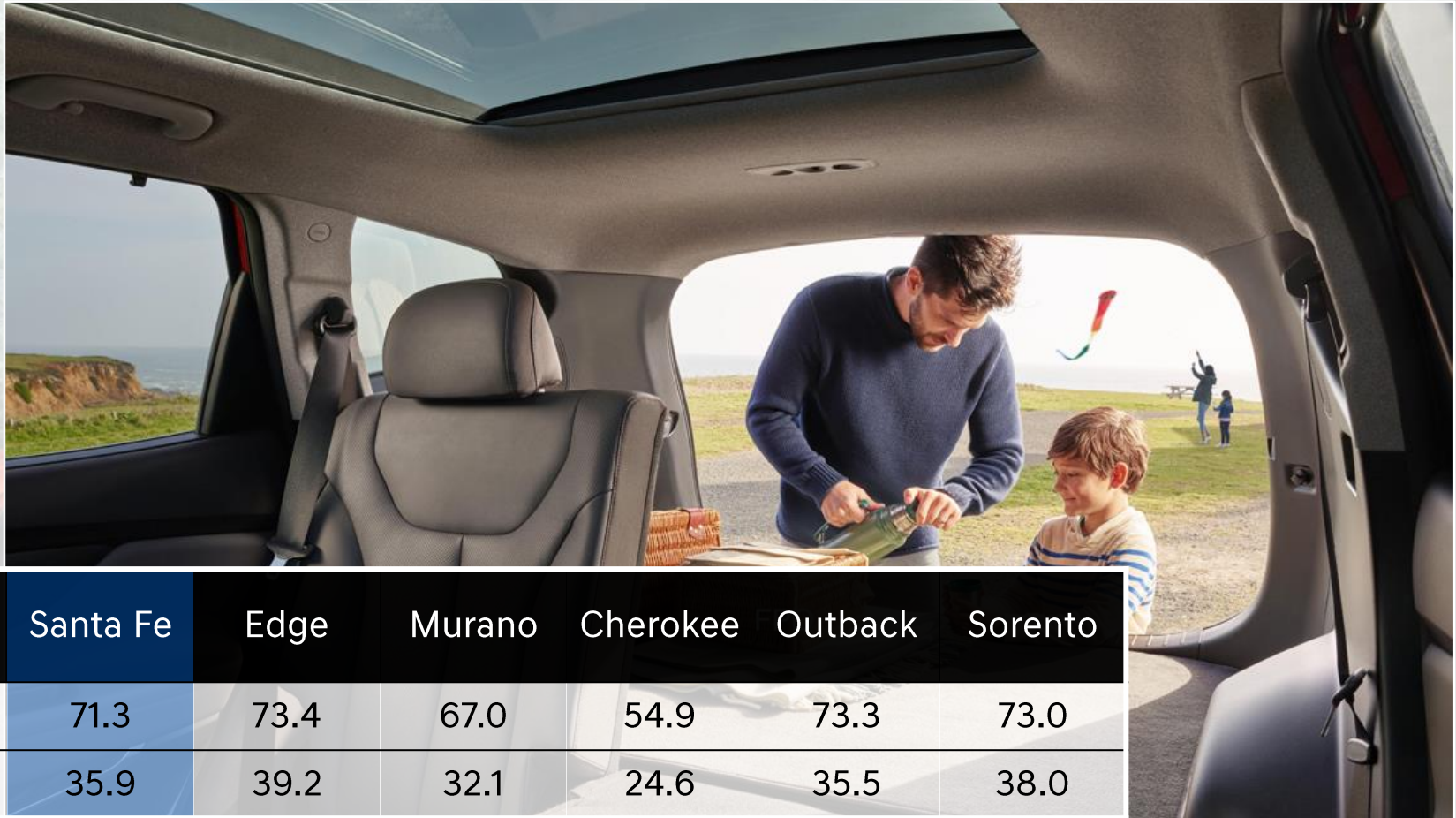

Interior Volume (ft ³)	Santa Fe Sport	Santa Fe	Edge	Murano	Cherokee	Outback	Sorento
Cargo Behind Front Seats	71.5	71.3	73.4	67.0	54.9	73.3	73.0
Cargo Behind 2 nd Row	35.4	35.9	39.2	32.1	24.6	35.5	38.0

*JATO V5

CAPABLE POWERTRAINS

ENGINE

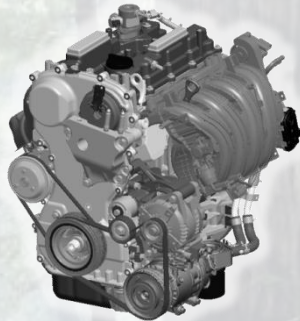

2.4L GDI 4-cylinder



2.0L Turbocharged GDI 4-cylinder

TRANSMISSION

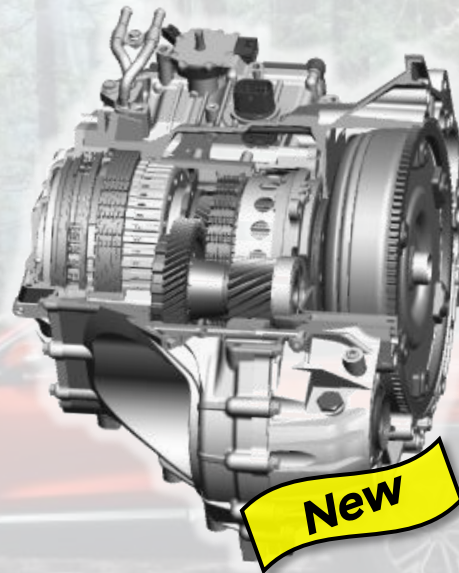

8-speed Automatic Transmission with SHIFTRONIC® Manual Shift Mode

DRIVE TYPE

Available HTRAC AWD



New

IDLE STOP & GO



Standard with both 2.4L and 2.0L Turbo engines

IMPROVED ENGINES

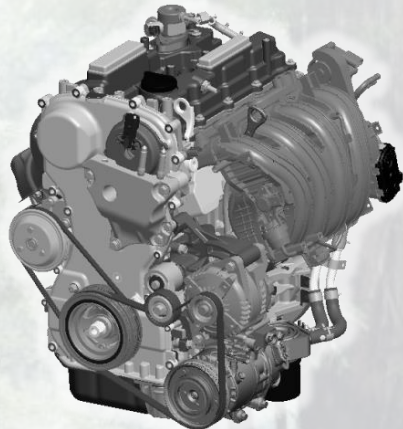

2.4L GDI 4-cylinder Engine with 8-speed A/T

185 HP @ 6,000 rpm

178 lb.-ft. torque @ 4,000 rpm

22 / 29 / 25 MPG FWD



2.0L Turbo GDI 4-cylinder Engine with 8-speed A/T

235 HP @ 6,000 rpm

260 lb.-ft. torque @ 1,450~3,500 rpm

20 / 25 / 22 MPG FWD

- ★ Both engines apply new electrically-actuated continuously variable valve timing technology (E-CVVT), improving overall fuel economy and performance.

8-SPEED A/T FOR 2.0T ENGINE

Direct Control Valve Body

Control valve reduction (20 → 12)

Improves efficiency by reducing valve body leakage flow

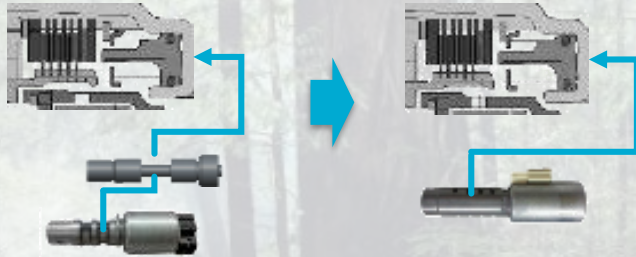

Dual Ball Bearings

Improves efficiency by reducing friction loss on roller contact area



Optimized Oil Pump Capacity

Improves efficiency by reducing pump capacity
Capacity Reduction by 43%



Multi-Plate Torque Converter

Improves response by expanding direct coupling area

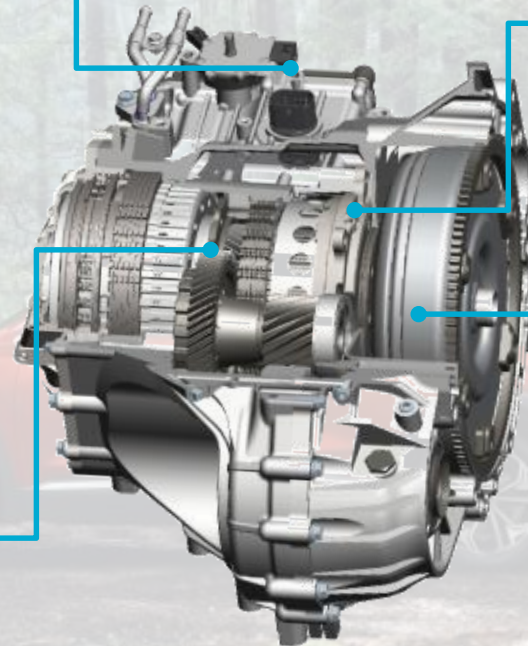
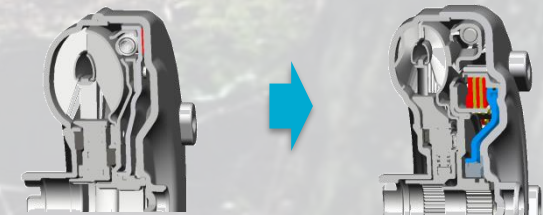

8-SPEED A/T FOR 2.4L ENGINE

6-Speed → 8-Speed

Extended driving range with gear ratio width

Delivers acceleration performance at lower gears and fuel efficiency in higher gears

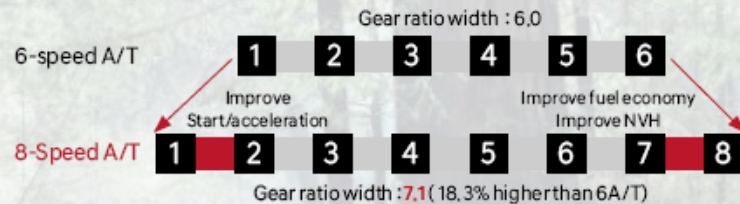

One-Way Clutch Delete

Reduced friction loss with 0.5% improved efficiency



Reduced Tapered Bearing Rollers

Reduced number of rollers (21 → 16) improving efficiency by 0.15%

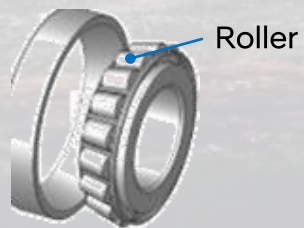

Fuel Efficient ATF Type

Improved drag during low temperature and warm up by 0.3%

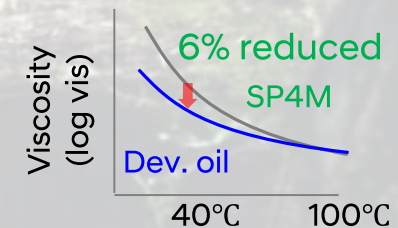

SUPERIOR HTRAC AWD PERFORMANCE

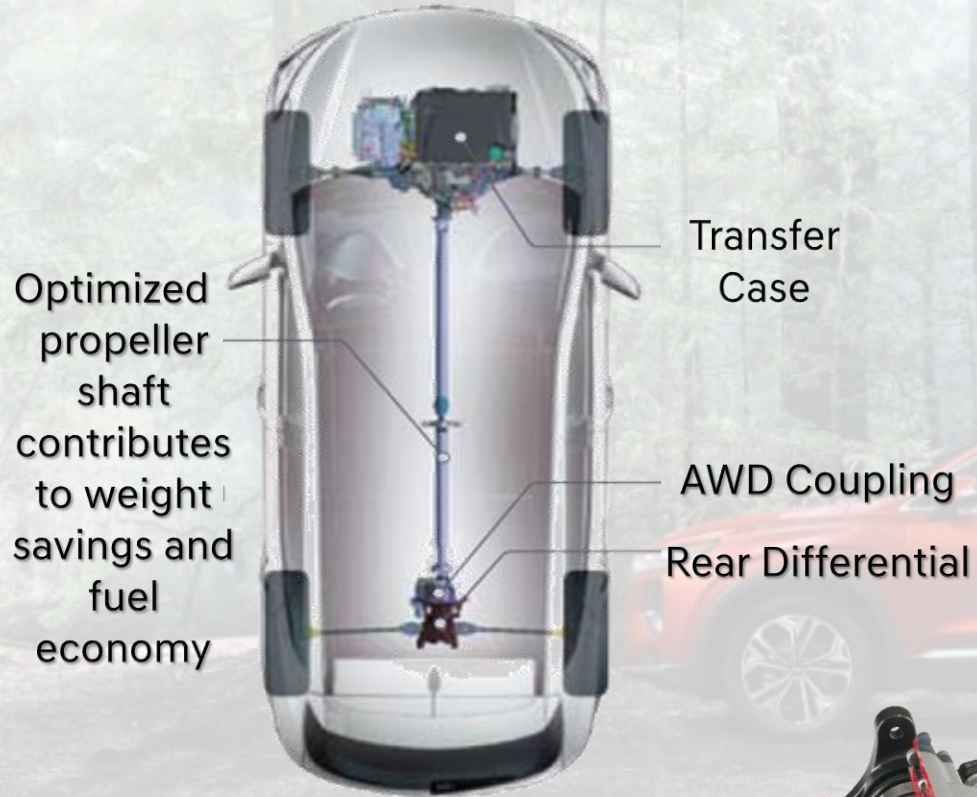

AWD Coupling

The electronic coupling device mounted between the front and rear axle actively distributes power.

Torque Vectoring

Braking force controls the wheels to ensure maximum passenger safety even when turning in unstable roads.

Optimum Distribution

Optimum driving force is distributed to front and rear wheels by intelligently monitoring road and vehicle condition.

Linked Drive Mode

By varying the driving force distribution according to drive mode, the system delivers enhanced driving characteristics.

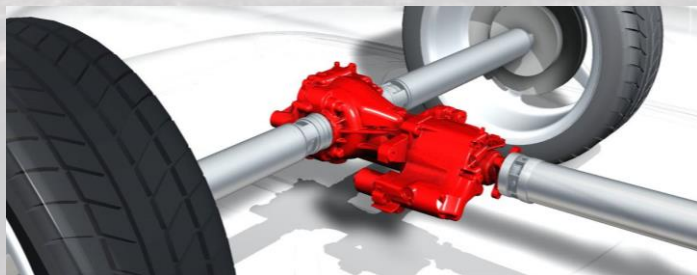

HTRAC

DYNAMAX
True AWD. Continuously thinking forward.

MAGNA
MAGNA POWERTRAIN

MORE PREDICTIVE HTRAC AWD SENSORS

50 VEHICLE INPUT SIGNALS calculate torque split and are transmitted & processed 100 times per second.



Driver

- Throttle
- Brake
- Steering
- Transmission
- Drive Mode setting
- ESP status



Engine

- Engine speed
- Engine torque
- Engine temperature



Transmission

- Selected gear
- Actual gear
- Torque converter status
- Clutch status



ESP

- Longitudinal acceleration
- Lateral acceleration
- Yaw rate
- Brake pressure
- Intervention status
- Friction coefficient



Environmental

- Outside temperature
- Windshield wiper status

IMMEDIATE HTRAC AWD COUPLING

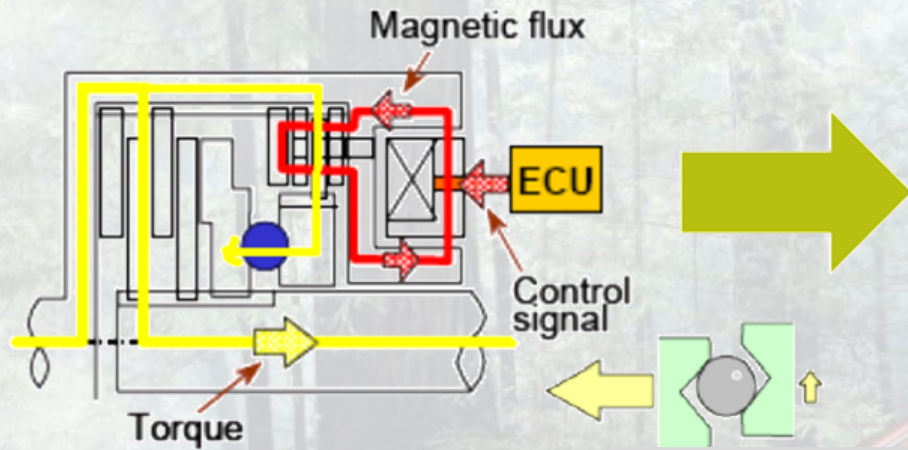

Standard Coupling

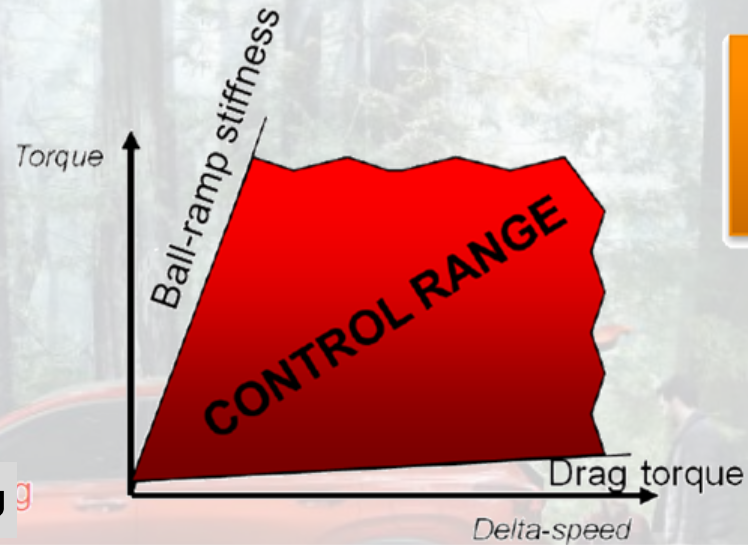

Standard Coupling
Delta Speed necessary to enable torque build up

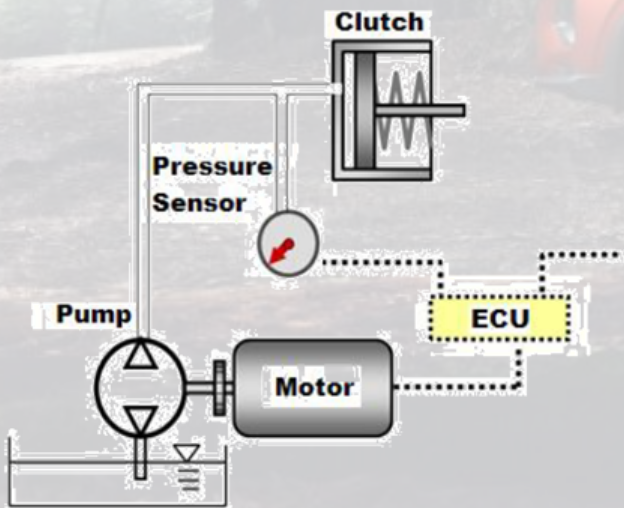

Dynamax Coupling

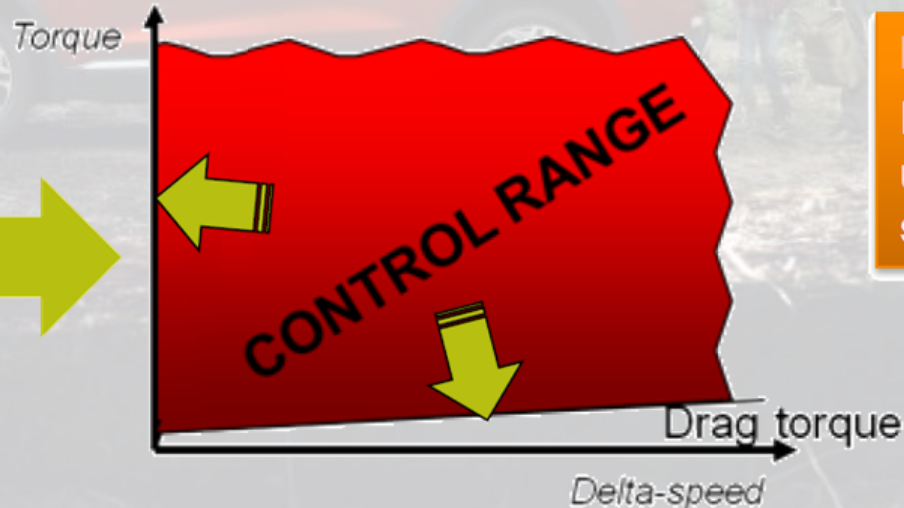

Dynamax Coupling
Immediate torque build up without need of delta speed on the coupling

Hyundai 1st
Linked AWD + Drive Mode

HTRAC OPTIMIZED WITH DRIVE MODES

HTRAC system tracks vehicle speed and road conditions to control braking between the left and right wheels. It balances power between the front and rear wheels to ensure safety while delivering superior cornering and driving dynamics on multiple road surfaces.



HTRAC driving force distribution by drive mode

Drive Mode	Optimizes	Torque Distribution (% Front:Rear)	Cluster Image
Comfort	Stable driving dynamics	Variable torque output to rear axle up to 50%, depending on HTRAC's continuously monitored inputs	
Smart	Fuel efficiency		
Sport	Acceleration and sporty dynamics	65 : 35 ~ 50 : 50	

IMPROVED DRIVE ASSIST LOGIC

Drive assist and drivability improvement logic

- The assist logic is differentiated according to drive mode, providing differentiated drivability and acceleration feeling

Optimal shift-point control during braking

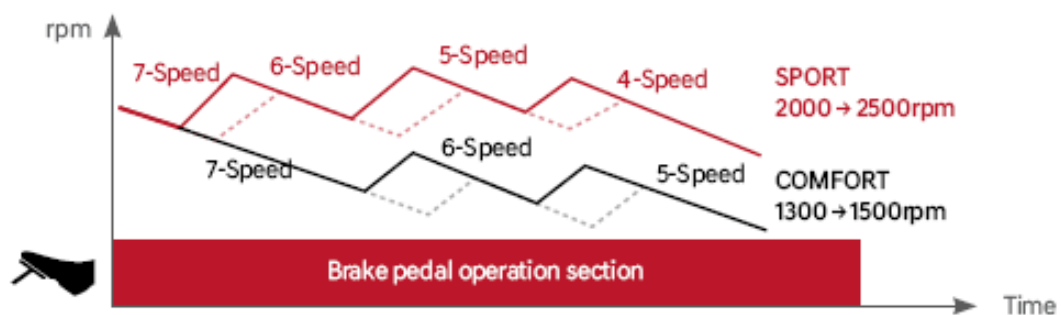

Provides improved responsiveness when re-accelerating by shortening the shifting point to the lower range during braking

Up-shift control during turning

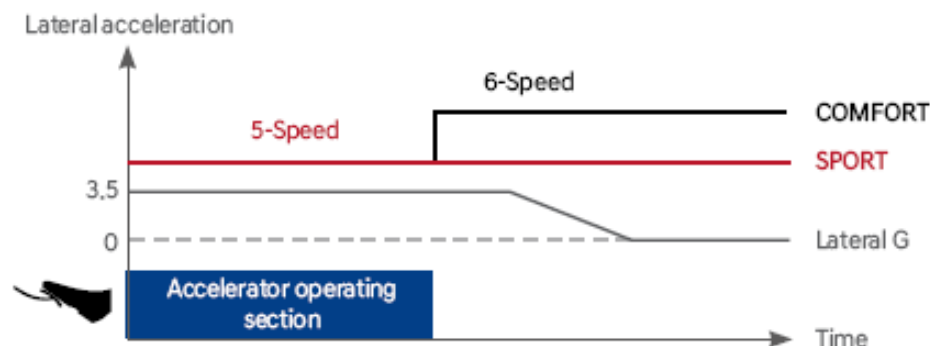

Improved acceleration response and driving stability by suppressing shifting to higher speed range during cornering

67% ADVANCED HIGH STRENGTH STEEL

Average Tensile Strength (Kgf/mm²)*



Hot Stamped Parts

- | | |
|---|--|
| 1 | Reinforced-Side outer, L/R |
| 2 | Reinforced-A Pillar, L/R |
| 3 | Reinforced-B pillar, L/R |
| 4 | Member center floor upper, L/R |
| 5 | Member assembly-front side rear lower, L/R |
| 6 | Member assembly-rear floor side front, L/R |
| 7 | Panel assembly-side sill inner rear, L/R |
| 8 | Front bumper beam |

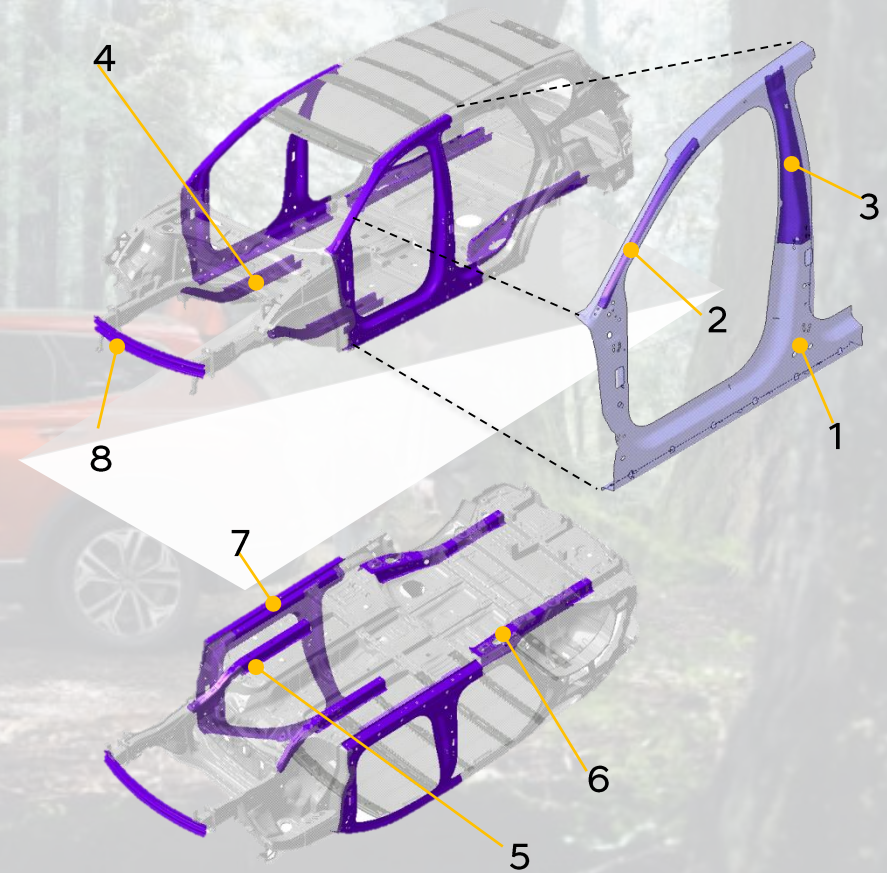

* Kilograms-force Per Square Millimeter

45% MORE STRUCTURAL ADHESIVE

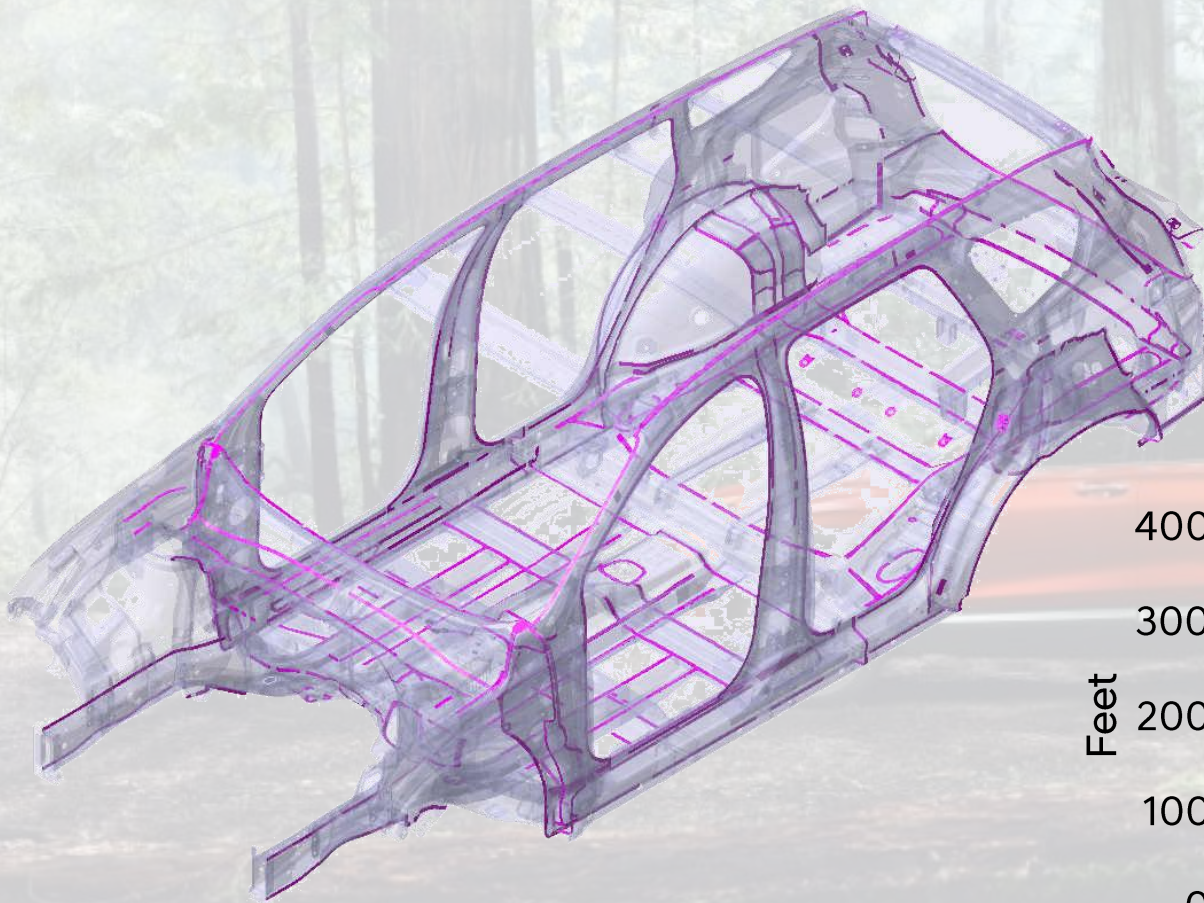

Structural Adhesive Benefit Example	Santa Fe
Primary mass reduction	51.9 lbs.
Total weight savings <i>(incl. weight decomposing)</i>	88.1 lbs.
Improvement in fuel efficiency	1.46%
Reduction of carbon dioxide	169.0 lbs./yr.

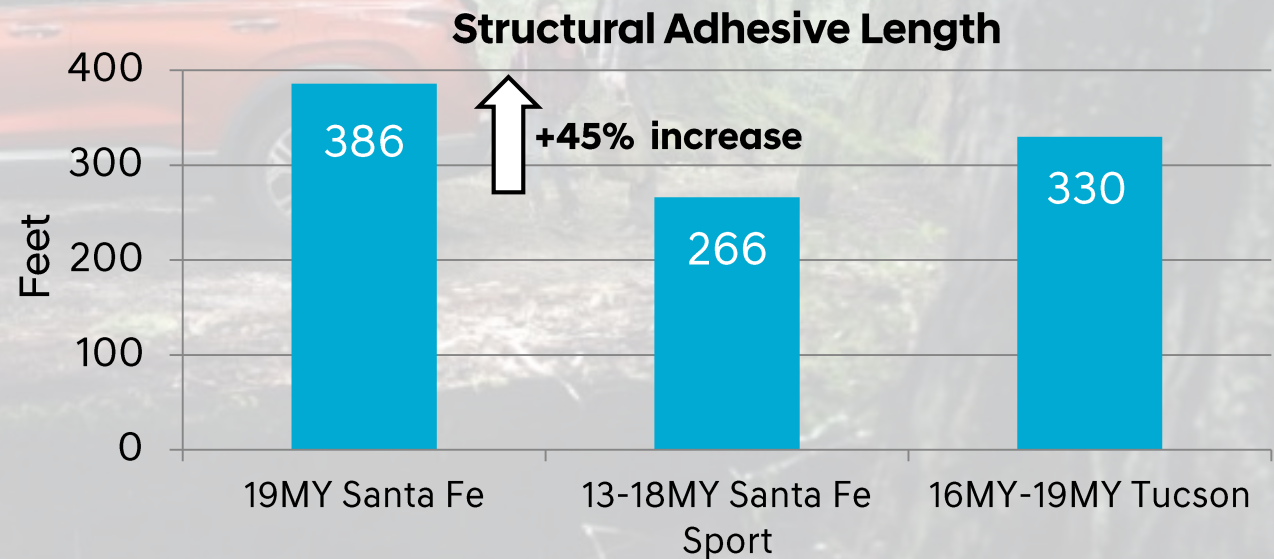



HYUNDAI



HYUNDAI



Trevor Lai
Manager, Product Planning

IMPROVED RIDE QUALITY

Torsional Stiffness (10,000 kgf·m² /rad)

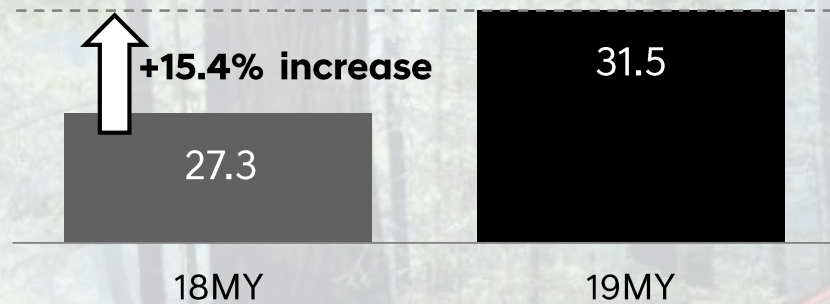

Cabin Area Joint Reinforcement

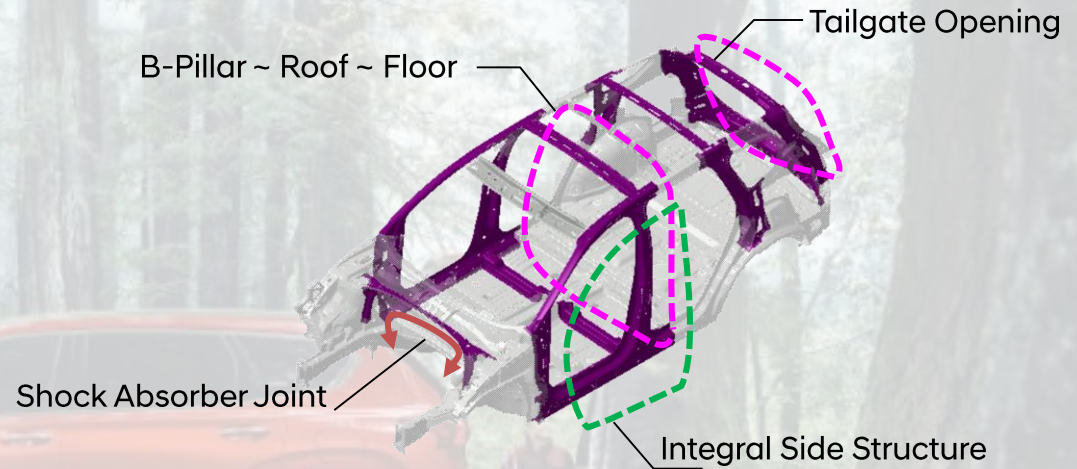

Upright Rear Shock Absorber

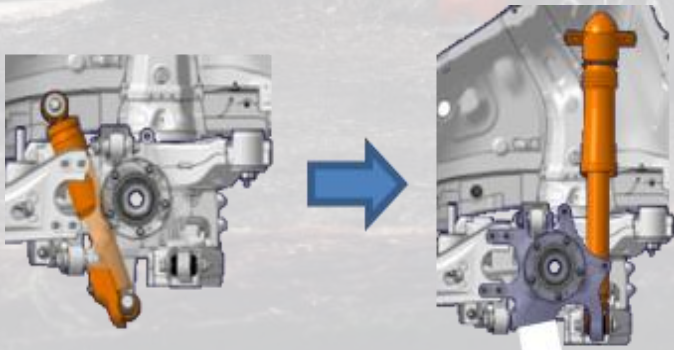

Interior/Exterior Rear Seat Joint Reinforcement

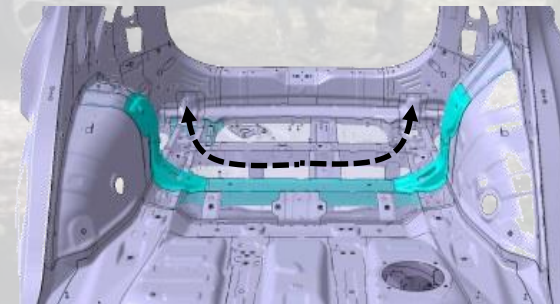

REFINED HANDLING

SUSPENSION BUSHING

★ Improved agility and vibration/shock absorption

G bushing diameter and void gap

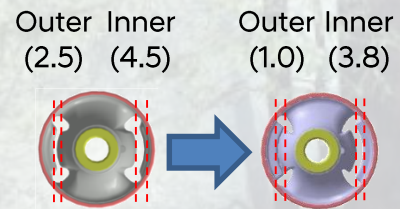

		Santa Fe	18MY	19MY
G Bushing	Diameter		Φ70	Φ68
	Hardness		Hs70	Hs65
	Void Gap		2.5 / 4.5	1.0 / 3.8

Updated trailing arm bushing diameter

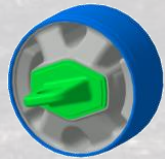

		Santa Fe	18MY	19MY
Trailing Arm Bushing	Diameter		Φ83	Φ80
	Hardness		Hs63	Hs55

STEERING SYSTEM

★ Improved agility and vibration/shock absorption

Better steering response with increased gear ratio and MDPS torsion bar stiffness

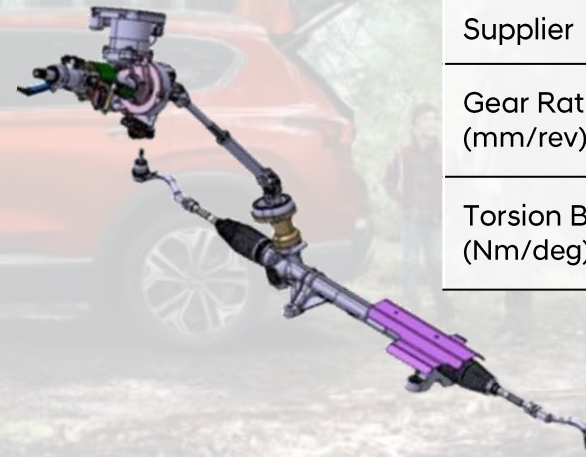

	Santa Fe	18MY	19MY
Supplier		Mobis/Mando	Mando
Gear Ratio (mm/rev)		54.2	56
Torsion Bar (Nm/deg)		2.5	2.8

IMPROVED SUSPENSION

Front

McPherson Strut with aluminum knuckle

Enhanced Geometry

- Improves responsiveness
- Reduces rolling behavior
- Improves steering responsiveness

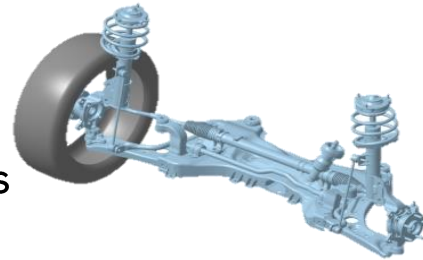

Enhanced Strut & Insulator Performance

- New upper/low spring perch connection structure
- Deleting fore/aft voids in the insulator

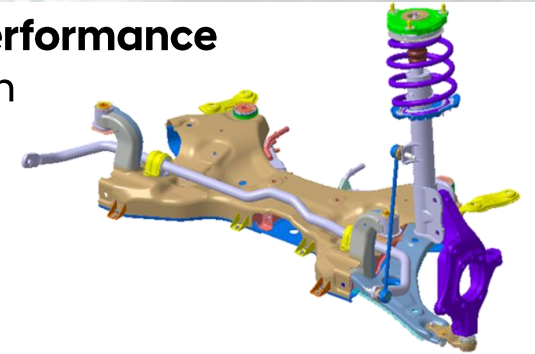

Strengthened Aluminum Knuckle Structure

- Steel → Aluminum
- Improved structural robustness

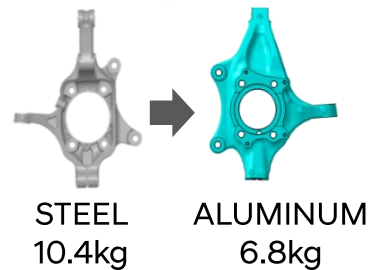

Improved Shock Absorber

- Enhanced driving dynamics and ride comfort

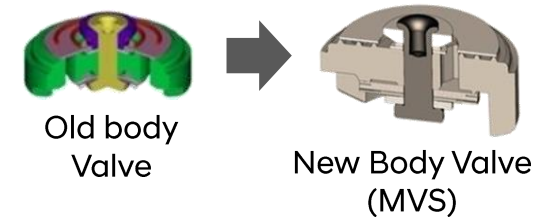

IMPROVED SUSPENSION

Rear

Multi-Link with aluminum carrier

Improved Suspension Structure

- Better impact damping

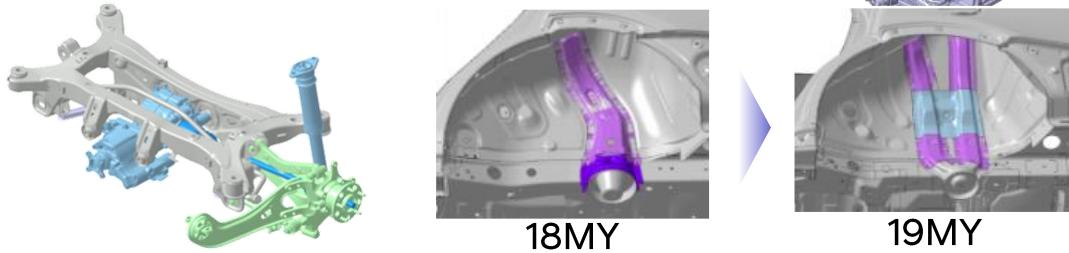

Strengthened Aluminum Carrier Mount

- Steel → Aluminum
- Increased caliper mount thickness reduces NVH

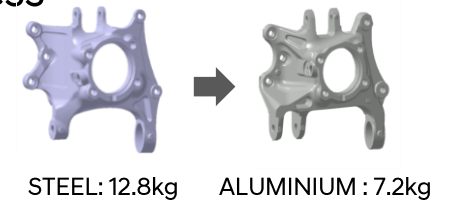

Improved Understeer with Better Toe Linearity

- Optimized turning stability and steering linearity

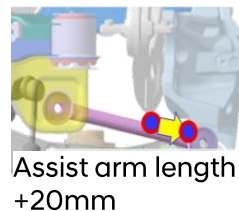

Optimized Cross-Member Mount Bushing

- Bushing size increased $\Phi 72 \rightarrow 74.5\text{mm}$
- Flat type → Reverse bulge
- Improves ride comfort and reduces road noise



MORE INSULATION MATERIAL

Extensive use of sound-absorbing material

Significant reduction in engine and driving noise due to expansion of sound absorbing materials for noise-sensitive parts of the car body

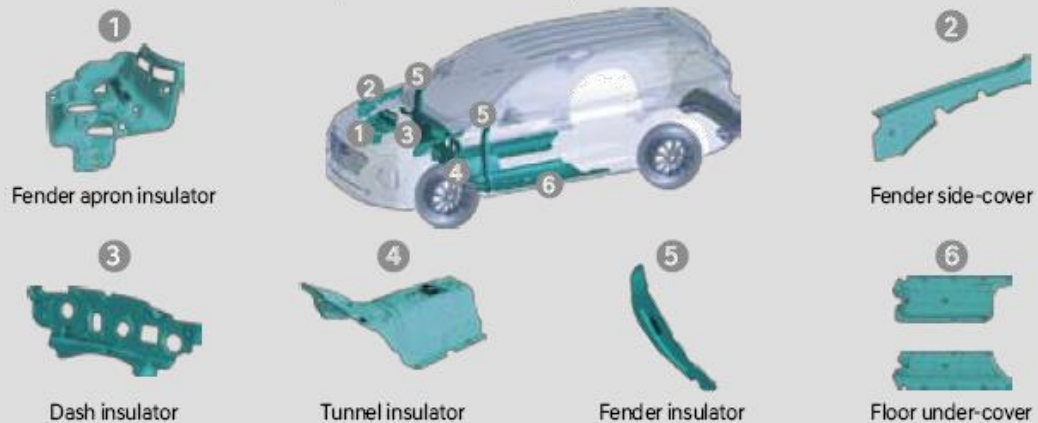

Optimization of floor panel & damping pad

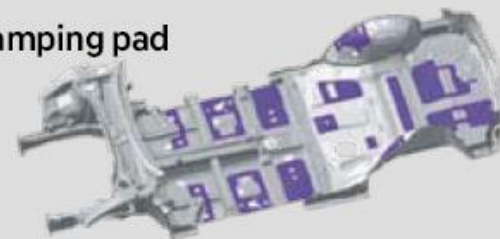

Dash sound insulation pad

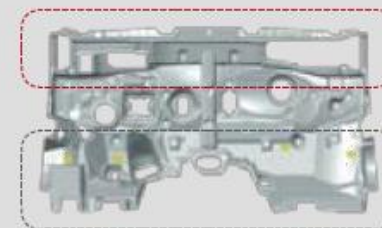

Expanded use of foam pad



Minimize body hole



Other measures to reduce N V H



Exhaust valve inside exhaust canister



Floor Panel reinforcement



More laminated glass





RR cross-member bushing shape

SEAT OPTIMIZATION

VARIABLE-DENSITY SEATS

Front seats apply various density levels to improve overall seating comfort and support

-  **Main cushion/back:** medium firmness
-  **Bolster:** maximum firmness
(improves lateral support)
-  **Front cushion/seatback:** softest
(improves thigh pressure and back support)



8-WAY POWERED FRONT SEATS WITH DRIVER SEAT CUSHION EXTENSION

- ❶ Sliding
- ❷ Reclining
- ❸ Cushion tilt and height adjustment



Power cushion extension enhances thigh support for drivers

TARGETS NHTSA 5-STAR & IIHS TSP+

Body structure performance prioritizes passenger safety in case of a collision

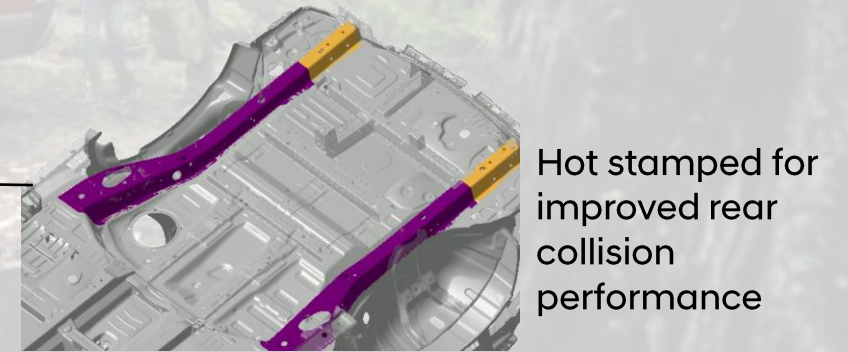
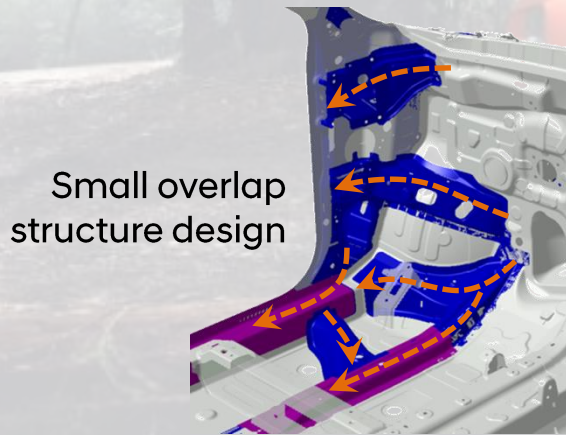
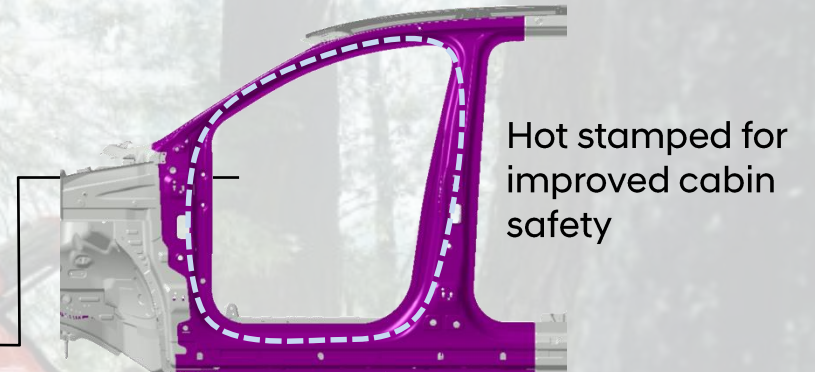
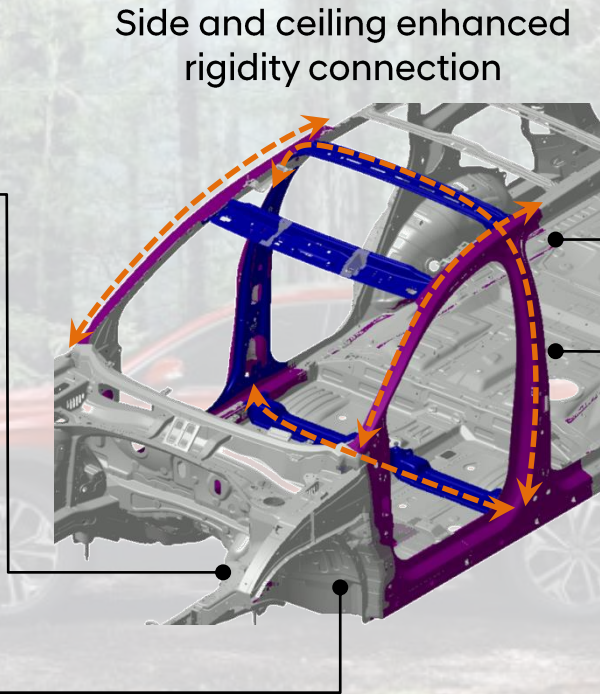
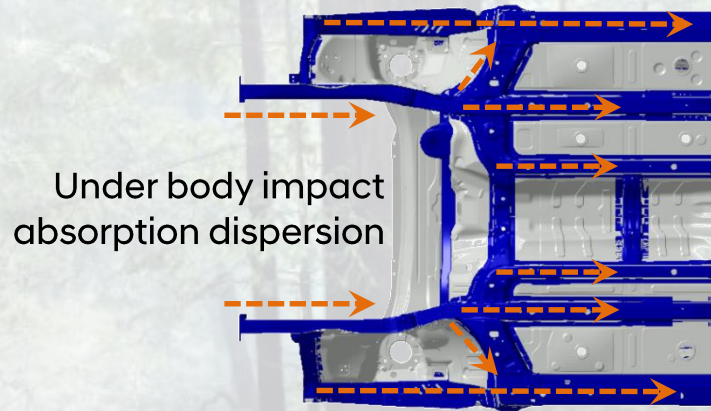

Hyundai SmartSense



STANDARD SAFETY FEATURES

- 1 Forward Collision-Avoidance Assist w/ Pedestrian Detection
- 2 Blind-Spot Collision-Avoidance Assist
- 3 Lane Keeping Assist
- 4 Rear Cross-traffic Collision-Avoidance Assist
- 5 Safe Exit Assist
- 6 High Beam Assist
- 7 Smart Cruise Control w/ Stop & Go
- 8 Driver Attention Warning

ADVANCED SAFETY COMPARISON

● Standard / ○ Optional

Safety Features	Santa Fe	Edge	Murano	Cherokee	Outback	Sorento
Forward Collision-Avoidance Assist	●	●	●	○	●	○
<i>FCA with Pedestrian Detection</i>	●	●	n/a	n/a	n/a	○
Blind-Spot Collision-Avoidance Assist	●	● (Warning)	○ (Warning)	○ (Warning)	○ (Warning)	● (Warning)
Smart Cruise Control with Stop & Go	●	○ (Adaptive)	○	○	● (Adaptive)	○
Lane Keeping Assist	●	●	n/a	○	●	○
Rear Cross-traffic Collision-Avoidance Assist	●	● (Warning)	○ (Warning)	○	○	● (Warning)
Driver Attention Warning	●	●	○	n/a	n/a	○
High Beam Assist	●	●	n/a	○	○	○
Rear Occupant Alert	○	n/a	n/a	n/a	n/a	n/a
Safe Exit Assist	●	●	n/a	n/a	n/a	n/a

*AutoPlanner

AVAILABLE CONVENIENCE FEATURES



- ★ Heads-up Display
- ★ Wireless Device Charging
- ★ Heated Front/Rear Seats
- ★ Ventilated Front Seats
- ★ Integrated Memory System
- ★ Surround View Monitor
- ★ Rain-Sensing Wipers
- ★ Panoramic Sunroof
- ★ LED Illumination
- ★ Rear Window Sunshades
- ★ Hands-Free Smart Liftgate
- ★ Side Mirror Approach Lights
- ★ Acoustic Laminated Glass
- ★ And more...

AVAILABLE INFOTAINMENT

8-inch Multimedia Navigation System

with an upgraded processor for greater responsiveness; HD Radio Traffic & Info

Infinity® Premium Audio

with 12-speakers including subwoofer plus

QuantumLogic® Surround Sound & Clari-Fi™ Music Restoration Technology

Next Generation Blue Link®

with Smart Watch and Alexa Integration



Apple CarPlay



androidauto



BLUE LINK[®] CONNECTED CAR SYSTEM

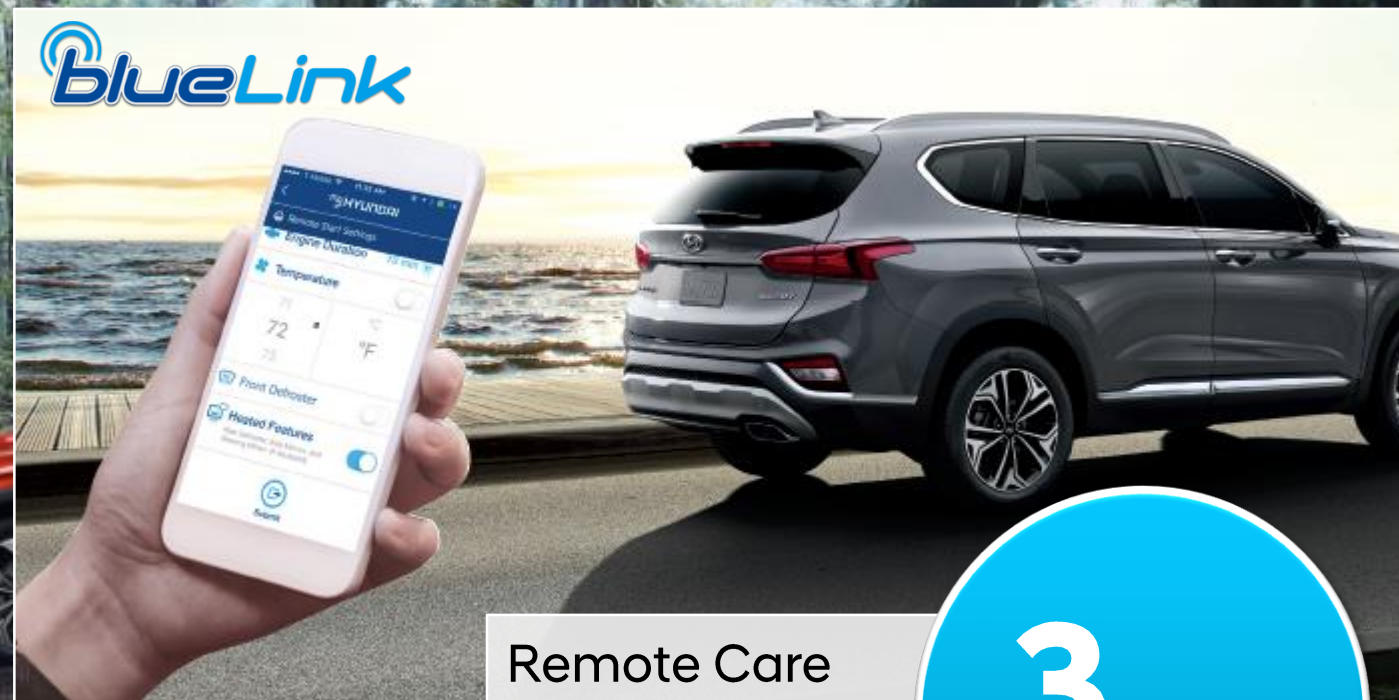
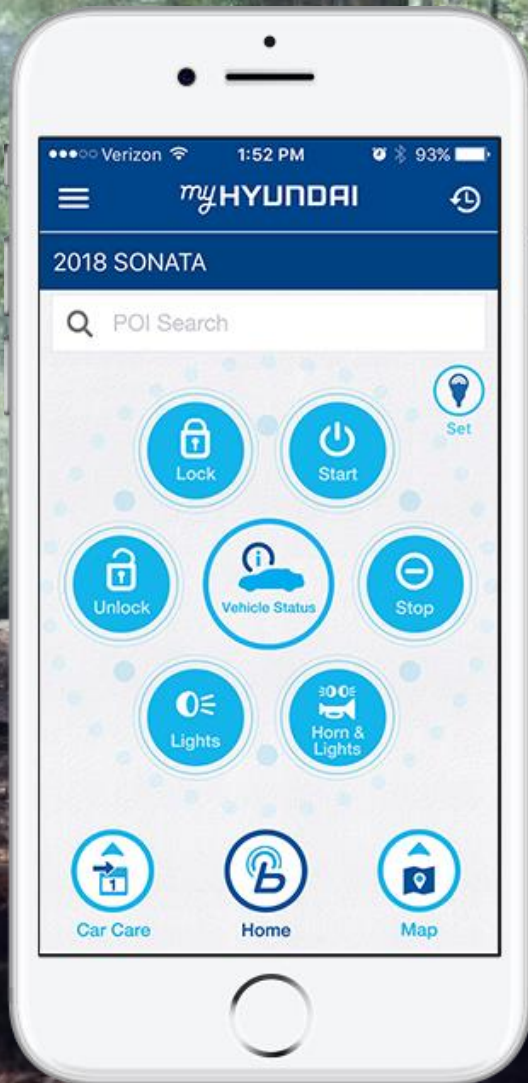

Remote Care
Remote Access
Guidance

3 YEARS
COMPLIMENTARY

12 MILLION REMOTE STARTS IN 2017

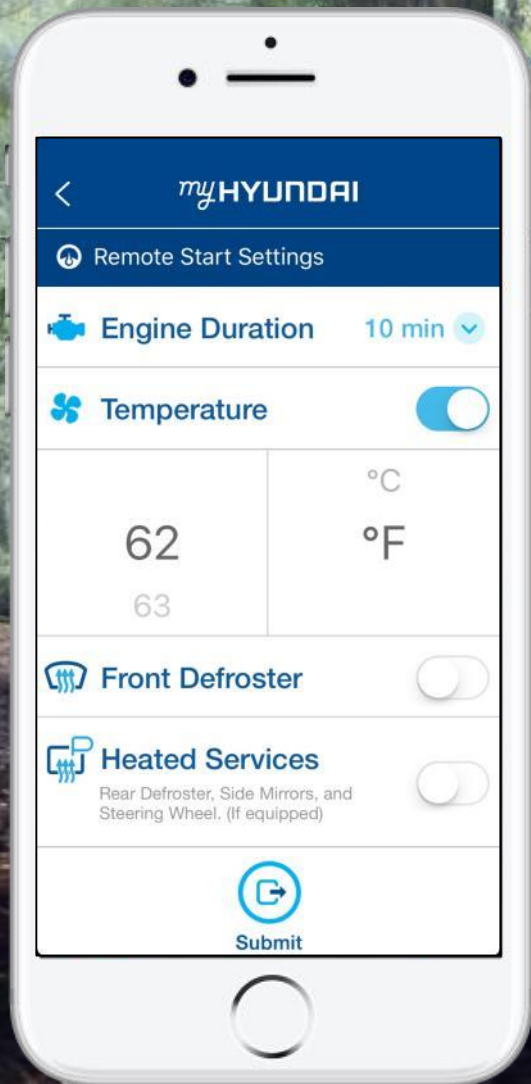

REMOTE SERVICES AVAILABLE VIA

amazon alexa

Google Home

Android & Apple Watch Apps

This graphic features a silver smartwatch with an Apple Watch-style interface, a white Google Home smart speaker, and two Amazon Alexa smart speakers (one blue, one black). The background is a blurred image of a red car in a forest.

TRIM STRATEGY



- ★ **Standard** 2.4L GDI 4-cylinder Engine with Idle Stop & Go (ISG) and 8-speed A/T
- ★ **Optional** 2.0L Turbocharged GDI 4-cylinder Engine with Idle Stop & Go (ISG) and 8-speed A/T

PACKAGING & PRICING

SE

\$25,500 MSRP

Standard features:

- 2.4L 4-cyl engine with Idle Stop & Go and 8-speed A/T
- 7" LCD touchscreen display
- Android Auto™ & Apple CarPlay™
- Hyundai SmartSense
 - ✓ Forward Collision-Avoidance Assist w/ PD
 - ✓ Blind-Spot Collision-Avoidance Assist
 - ✓ Rear Cross-traffic Collision-Avoidance Assist
 - ✓ Lane Keeping Assist
 - ✓ Safe Exit Assist

SEL

\$27,600 MSRP

SE features, plus:

- Drive Mode Select
- Proximity Key with Push Button Start
- Door handle welcome lights
- Side mirror approach lights
- 8-way power driver seat plus 2-way lumbar support
- Heated front seats
- SiriusXM and HD Radio
- Blue Link® Connected Car

SEL Plus

\$29,800 MSRP

SEL features, plus:

- Rear Occupant Alert
- 18" alloy wheels
- Hands-free Smart Liftgate
- Dual automatic temperature controls
- 2nd row cargo area releases
- Auto-dimming inside rearview mirror
- Infinity® premium audio with Clari-Fi™ and QuantumLogic® surround

Limited

\$32,600 MSRP

SEL Plus features, plus:

- Panoramic sunroof
- LED cabin lights, headlights, taillights and foglights
- Leather seating surfaces
- 8-way power passenger seat with height adjustment
- Side mirrors with turn signal indicators

Optional for Limited & Ultimate

- 2.0L Turbo GDI 4-cyl engine with Idle Stop & Go (ISG)
- 8-speed automatic transmission
- 19" alloy wheels

Ultimate

\$35,450 MSRP

Limited features, plus:

- Surround View Monitor
- 8" LCD touchscreen display with Navigation
- Integrated memory system for driver seat
- Ventilated front and heated rear seats
- Heads-up display and wireless device charging

Available HTRAC All Wheel Drive adds \$1,700 MSRP

SANTA FE PRICE COMPARISON - SE

Safety Features	Santa Fe SE	Edge SE	Outback 2.5i	Sorento L
Base MSRP	\$25,500	\$29,995	\$26,345	\$25,990
MSRP + Freight	\$26,480	\$30,990	\$27,320	\$26,980
Hyundai Price Advantage		\$4,510	\$840	\$500
Engine	2.4L	2.0L Turbo	2.5L	2.4L
Transmission	8-A/T	8-A/T	CVT	6-A/T
Horsepower / Torque	185 / 178	245 / 275	175 / 174	185 / 178
Wheel Size	17"	18"	17"	17"
AWD	Optional	Optional	Standard	Optional
7-inch Display	●	4.2"	6.5"	●
USB Outlets	4	1	2	1
Automatic Emergency Braking	●	●	●	-
Blind Spot Warning w/Braking	●	-	-	-
Rear Cross-Traffic Braking	●	-	-	-
Smart Cruise Control w/ Stop & Go	●	-	●	-
Safe Exit Assist	●	-	-	-
Basic Warranty	5YR / 60K miles	3YR / 36K miles	3YR / 36K miles	5YR / 60K miles

*AutoPlanner

COLOR PALETTE

EXTERIOR

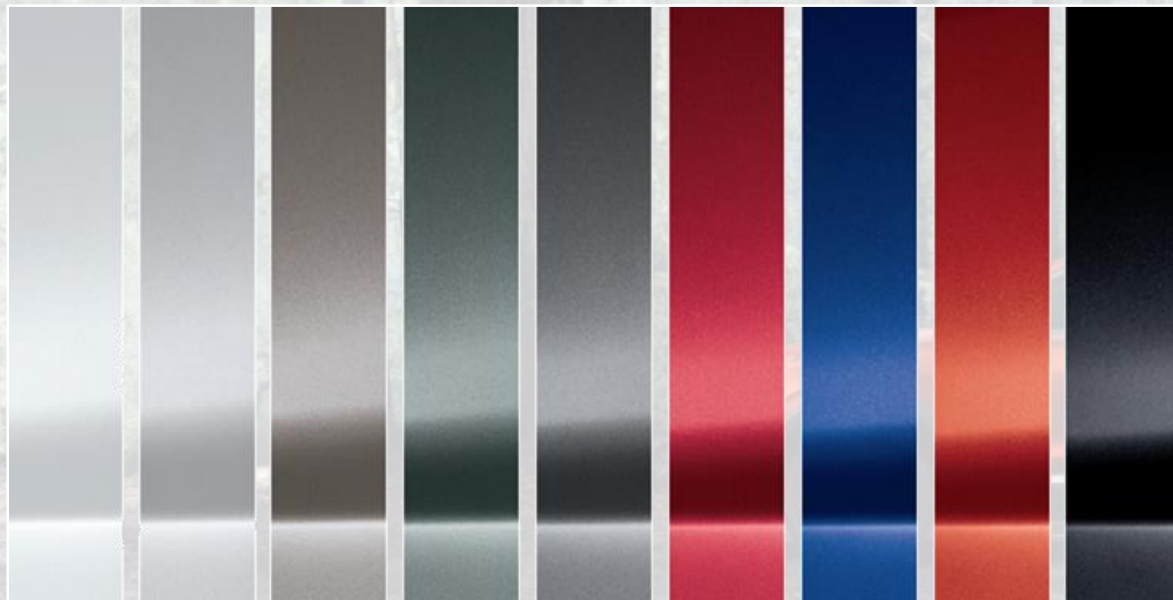

INTERIOR

Black

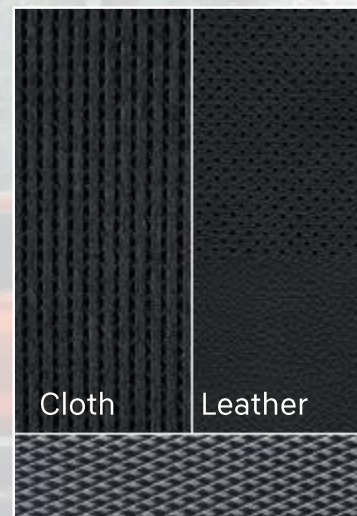

Metallic Accents

Beige

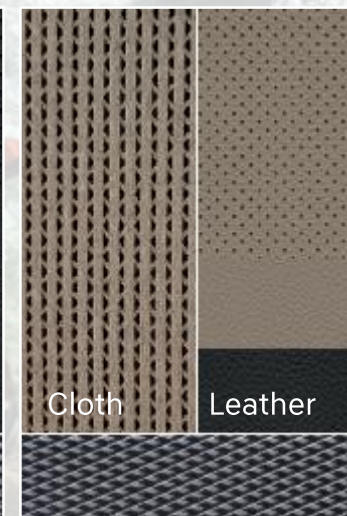

Gray



Gray Stone Accents

DARK CHROME TOUCHES

Twilight Black & Lava Orange exteriors apply dark chrome elements:



**Non-US Spec Shown*

2019 SANTA FE

- ★ Distinctive Styling
- ★ Capable Driving Dynamics with Turbocharged Engine and 8-speed A/T
- ★ Standard Hyundai SmartSense Features
- ★ Human Focused Technology & Connectivity





2019 SANTA FE

Chalk Talk

- Flash Drive – photography/video assets (includes Santa Fe Utah pictures)
- Emergency Contacts – included in each car
- Drive routes include twisty roads and elevation up to 9,753 feet
 - In the afternoon there is an optional off-road course
- Total drive is 176 miles
- The Santa Fes on the drive today will be 2.0T and HTRAC
 - The 2.4L is available at the hotel



• Be Safe



INSTAGRAM CHALLENGE



hyundaiusa



1,717,479 likes

hyundaiusa Exploring beautiful Park City in the all-new 2019 @HyundaiUSA Santa Fe! #FuelingQualityTime #HyundaiSantaFe

Best Photo/Video Contest Rules:

1. Must add both [#HyundaiSantaFe](#) AND [#FuelingQualityTime](#) hashtag
2. Tag [@hyundaiusa](#) in your post
3. All photos must be posted on Instagram **TONIGHT by 5PM Local Time**
4. Winner announced at dinner tonight.
5. Prizes: Amazon Gift Cards:
1st \$50, 2nd \$30, 3rd \$20

Have Fun & Enjoy Your Drive!

